

Product highlights ▾

- * Multilingual operation
- * Automatic built in test and self diagnosis
- * Secure access Key
- * Continuous working 10000 hours above
- * Threat alert and material classification
- * International standard configuration:
Japan Hamamatsu detection and UK Senstech board
- * Network-Ready
- * Energy saving design
- * One key turn off
- * Drugs and explosives inspection
- * Indication of the date and time

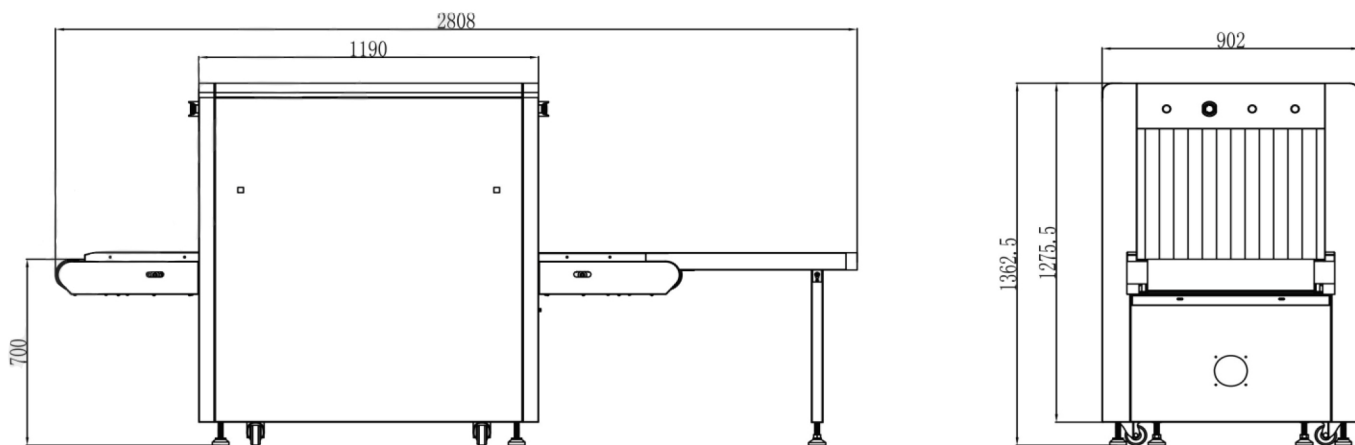

Dimensional Drawing ▾



Important Sizes :

Product Size: 2808* 902 * 1362.5mm (L × W × H)

Tunnel Size: 658* 500mm (width × height)

Product Details

General Specifications

Unit weight	475 kgs
Unit size	2808(L)*902(W)*1362.5(H) mm
Tunnel size(mm)	658(L)*500(W)
Conveyor Speed(m/s)	0.2
Conveyor height(mm)	695
Conveyor Max Load(kgs)	150
Penetration	Typical 32mm steel, guarantee 30mm steel
Wire Resolution	Typical AWG38, guarantee AWG36
X-Ray dosage each inspection	Typical 2.0 μ Gy/h, guarantee 2.5 μ Gy/h
Boundary Leakage	Typical 1.0 μ Gy/h, guarantee 1.5 μ Gy/h
Power consumption	Max.0.8KVA
S/N ratio	<60dB
Film Safety	Guarantee ASA/ISO1600 Film

Configuration

X-Ray generator	140KV, oil cooling, from bottom to top
Imaging System	Japan Hamatsu detector + UK Sens-tech PCBA
Computer	CPU: Intel Celeron 2.60-2.70GHz, hard drive 500G, Storage 2G
Monitor	Dell or Acer, 17" LED screen, resolution 1280*1024 pixels
Operation table	Single screen console
Keyboard	AT2005, designed by Safeway System
Operation System	Windows XP

Software

Image Enhancement	1-64times enlargement continuity, Color/BW, negative,high/lowpenetration, organic /inorganic Stripping, general enhancement, and pseudo color,etc.
Image Recall	30 preceding images recallable,retrieval.
Image Archive	Up to 50,000 images stored automatically, enable transferring to USB disk, and converting to JPG, BMP, XF, PNG, TIFF, GIF six formats.
Other Functions	Time/date display, counters, user management, system-on/X-ray-on timers, power on self test, built-in diagnostic facilities, dual-direction scanning, system log, system standby and stimulant training, ADS etc.
Network Applications	Multiple remote applications available based on Ethernet LAN and windows platform, such as image centralized storage and identify, recheck workstation, and network TIP, etc (Optional).

Operating Environment

Operation temperature/Humidity	5C-40C / 0%-90%(non-condensing)
Storage temperature/Humidity	-20C-60C / 10%-90%(non-condensing)
Operation Power	220VAC(\pm 10%) 50 \pm 3Hz (Optional: 100VAC,110VAC,120VAC,200VAC)



Robust Technologies India LLP

RZ-89, New Uttam Nagar, New Delhi - 110059

Ph: 9818521303, 09818821303, 08076552055

Email : info@robusttechnologiesindia.com, digitalindia99@gmail.,com

Website : www.robustscan.com, www.baggage-x-ray-scanner.com